

Interim Design

Team # 17

Michael Bunne, John Jagosztyn, and Jonathan Lenoff

Department of Mechanical Engineering, Florida State University, Tallahassee, FL

Project Sponsor:



Project Advisors:

Dr. Emmanuel G. Collins, Ph.D

Department of Mechanical Engineering

Dr. Oscar Chuy, Ph.D

Department of Mechanical Engineering

Introduction

Problem Statement

The current generation of assistive walking devices is limited in their traversable terrain and functionality.

- Indoor operation only
- Only perform basic functions
- Scooters / electric wheelchairs unnecessary or expensive

Proposed Solution

Develop a walking assistive device designed to actively assist the user in both indoor and outdoor maneuverability.

- Further empower the disabled and elderly community
- Offer wide-range of assistive functions
- Maintain ease of use and intuitiveness integral to current generation walkers



Specifications

Frame

- Resemble current generation walker in aesthetics and standards
- 1 inch diameter aluminum piping
- Supports up to 300 pounds
- Adjustable heights between 32 and 39 inches
- Adjustable handle width between 11 and 24 inches

Propulsion

- Minimum 11 inch diameter wheels or tracks
 - Travel over all indoor surfaces, grass, gravel, sand...
 - Travel up or down slopes up to 10 °
- Move transversely 45° from the center axis
- Maximum operating speed of 5 mph

Control & Function

- Intuitive user input
 - Force-based drive control
- Fall Prevention
- Sit-Down/Stand-Up Assistance
- Object Detection/Avoidance
- Localization & Navigation

Criteria

- **Versatility**
- **Robustness**
- **User-friendliness**
- **Indoor operation**
- **Outdoor operation**
- **Cost**
- **Weight**

Concepts

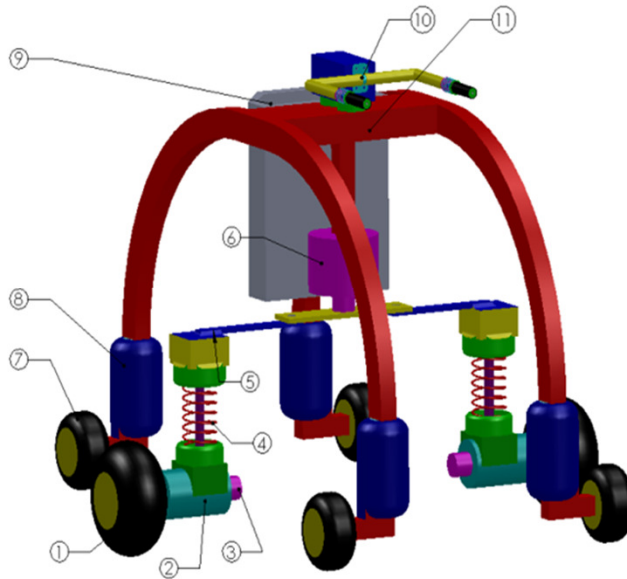

Concept 1:

1. 6 wheels
 - a) 2 driving, 4 passive
 - b) Air-filled
 - c) 30cm driving
2. 3 motors
 - a) 2 driving, 1 steering
 - b) Semi-omni-directional
3. Passive suspension
4. Force-plate driven
5. Passive dimension adjustment
6. Small payload capacity
7. Fall detection/Stand-up Assistance
8. Object avoidance

Concepts

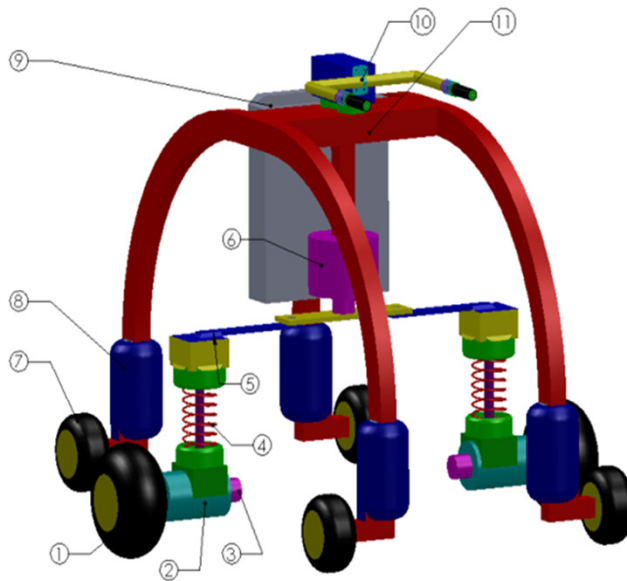

Concept 1:

Versatility – 3

Robustness – 4

User-friendliness – 3

Cost – 2

Indoor Operation – 3

Outdoor Operation – 4

Weight – 2

Concepts

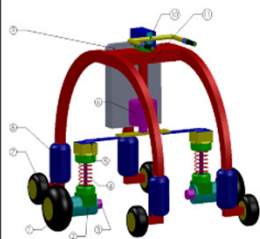
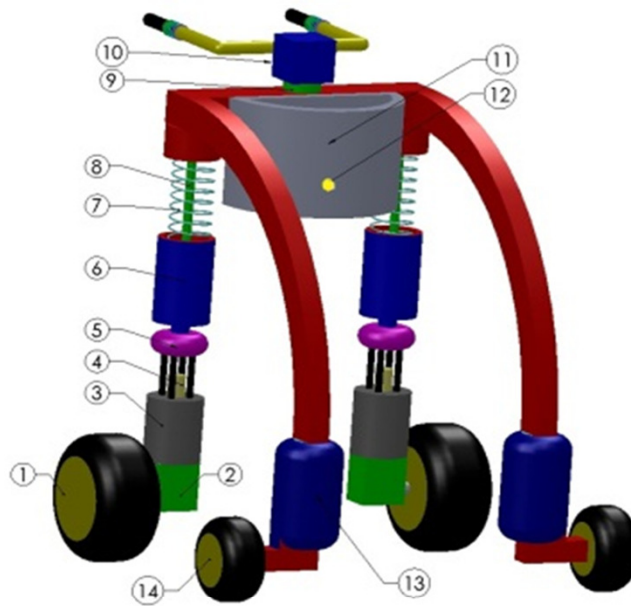

Concept 2:

1. 4 wheels
 - a) 2 driving, 2 passive
 - b) Honeycomb
 - c) 30cm driving
2. 4 motors
 - a) 2 driving, 2 steering
 - b) Omni-directional
3. Passive suspension
4. Spring-based driven
5. Passive dimension adjustment
6. Small payload capacity
7. Fall detection/Stand-up Assistance
8. Object avoidance

Concepts

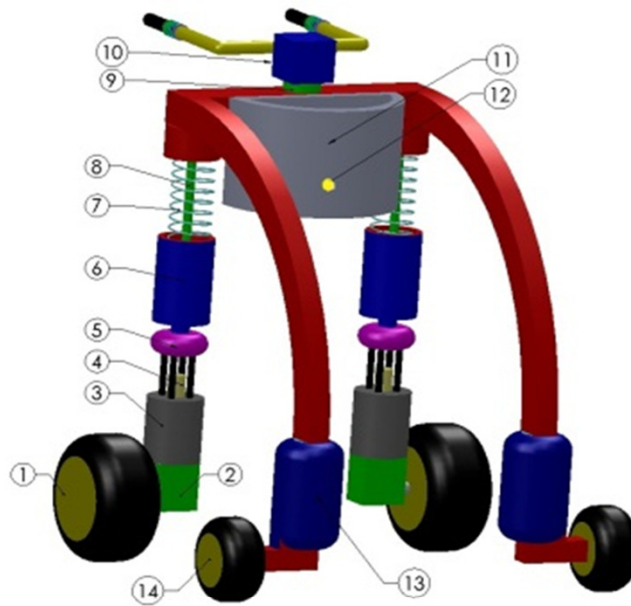

Concept 2:

Versatility – 5

Robustness – 3

User-friendliness – 4

Cost – 2

Indoor Operation – 3

Outdoor Operation – 3

Weight – 3

Concepts

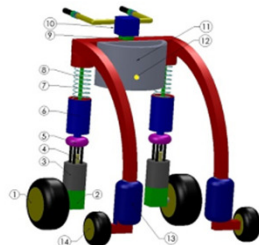
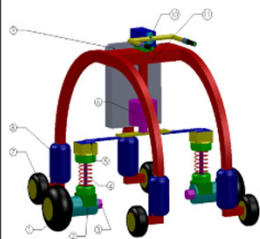
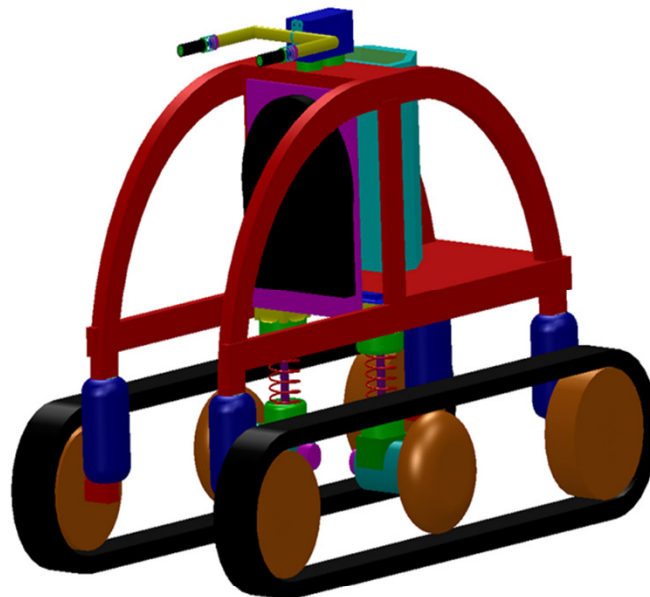

Concept 5:

1. Treads
2. 1 motor
 - a) 1 driving, skid steering
 - b) Semi-omni-directional
3. Active suspension
4. Spring driven
5. Passive dimension adjustment
6. Large payload capacity
7. Fall detection/Stand-up Assistance
8. Object avoidance
9. Riding Capability

Concepts

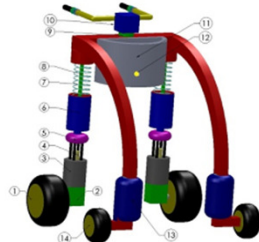
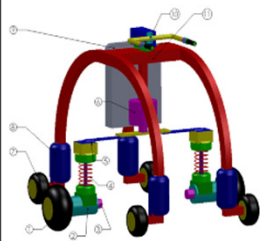
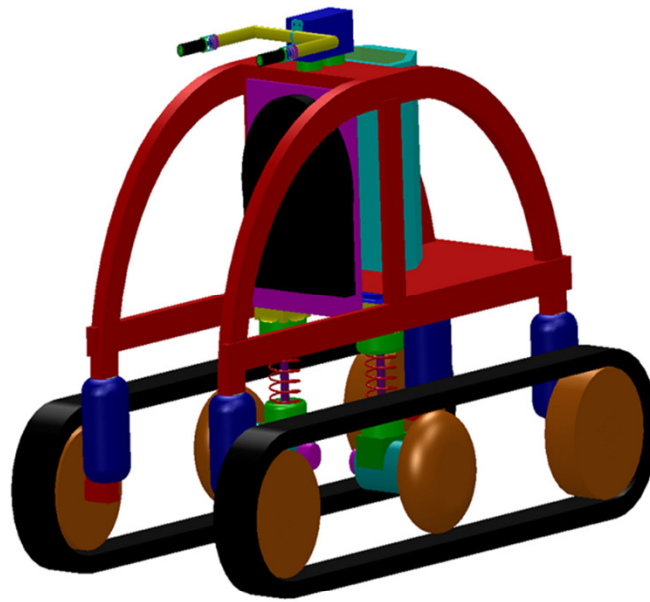

Concept 5:

Versatility – 3

Robustness – 4

User-friendliness – 3

Cost – 1

Indoor Operation – 1

Outdoor Operation – 5

Weight – 1

Concepts



Locomotion

Steering

Controls

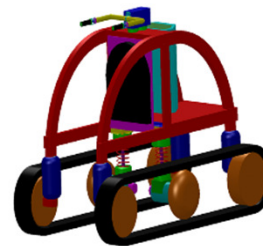
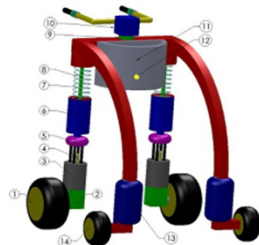
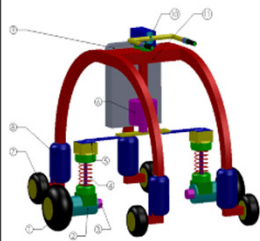

	Treads	Air Filled Tire	Honeycomb Tire
Average Life	75,000+ Miles	25,000+ Miles	25,000+ Miles
Traction	Very High	Average	Average
Outdoor Operation	High (Large footprint)	Average (High potential for slip, small footprint)	Average (High potential for slip, small footprint)
Indoor Operation	Low (Large footprint)	High (Small footprint)	High (Small Footprint)
Puncture Resistance	Highly Resistant	Mildly Resistant	Highly Resistant
Environment Conditions	All Conditions	Mud, Ice and Snow present potential issues	Mud, Ice and Snow present potential issues
Possible Failures	Cracked Tiles, chain or driving belt may come off	Exploding Tires (Over pressurized), tears or leaks that let out air	Chunks can be removed from tire
Possible Repairs	Replace Individual Tiles	Leak Stop, Foam Filling	Rubber like material to fill in gashes
Suspension Assistance	None	Average	High
Obstacle Traversability	Very High	Low	Average
Overall Complexity	High	Low	Low



	Ackerman Steering	Individual Steering Motors	Skid Steer
Necessity for additional support electronics	Low	High	Low
Size of Additional Motor Necessary	Large (Must steer both wheels)	Small (Load is split amongst motors)	None (Driving motors steer)
Capability for Use Unpowered/Broken	High	High	Very Low
Turning Radius	~5 ft min	0	0
Holographic Movement	No	Yes	No
“Module” Compatibility	No	Yes	Yes
Possible Failures	Joints or joining bar may deform or break	Rotary Connection may fail	Chain or driving belt may come off
Overall Complexity	Average	High	Low

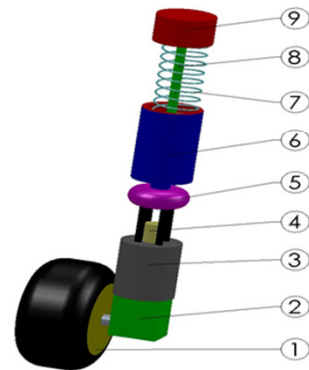
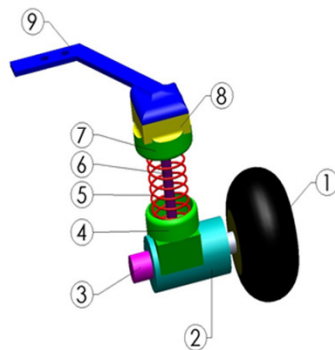

	Spring Driven Controls	Force Plate
Max Input Force	~500 Pounds	~5 Pounds
Part Replacement/Repair	Cost Effective and Easy	Expensive and Difficult
Moving Parts	Yes	No
Possible Failures	Potentiometers may break, springs may deform	Solid State electronics may be damaged
Environment Conditions	All Weather	Water must be kept away from force plate
Number of Input Axes	2	6
Overall Complexity	Low	High
Cost	Low (~\$100)	High (~\$5,000)

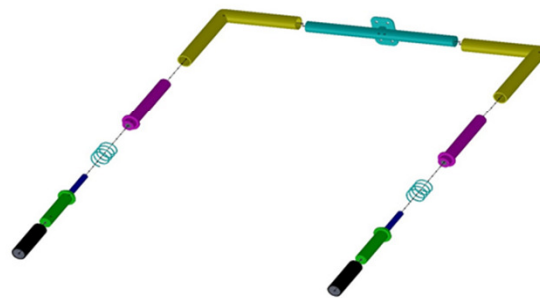

Spring Selection

At Equilibrium:

$$F = kx$$

$$F = mg$$

$$mg = kx$$

$$k = \frac{mg}{x}$$

In Motion:

$$m \frac{d^2 y}{dt^2} + c \frac{dy}{dt} + ky = 0$$

$$2\zeta\omega_n = \frac{c}{m} \quad \omega_n^2 = \frac{k}{m}$$

$$\frac{d^2 y}{dt^2} + 2\zeta\omega_n \frac{dy}{dt} + \omega_n^2 y = 0$$

$$t_{\text{settling}} = \frac{-\ln(\text{settlingRatio})}{\zeta\omega_n}$$

$$2\zeta\omega_n = \frac{-2\ln(\text{settlingRatio})}{t_{\text{settling}}} = \frac{c}{m}$$

$$c = \frac{-2m\ln(\text{settlingRatio})}{t_{\text{settling}}}$$

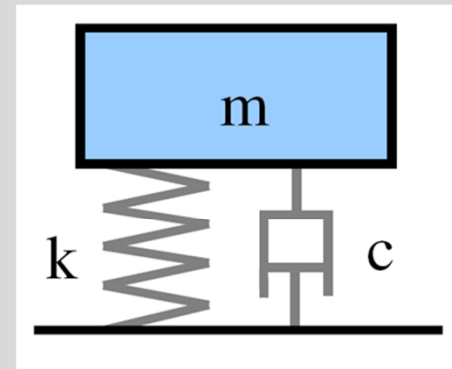
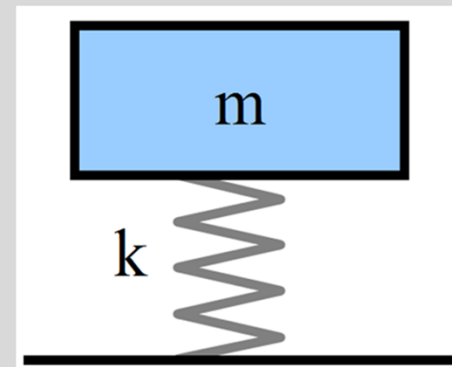

Motor Selection

Torque:

$$\tau_{\text{applied}} = F_{\text{applied}} * r$$

$$F_{\text{applied}} \geq F_{\text{friction}} = \mu_{\text{static}} * mg$$

$$\tau_{\text{applied}} \geq \mu_{\text{static}} * mg * r$$

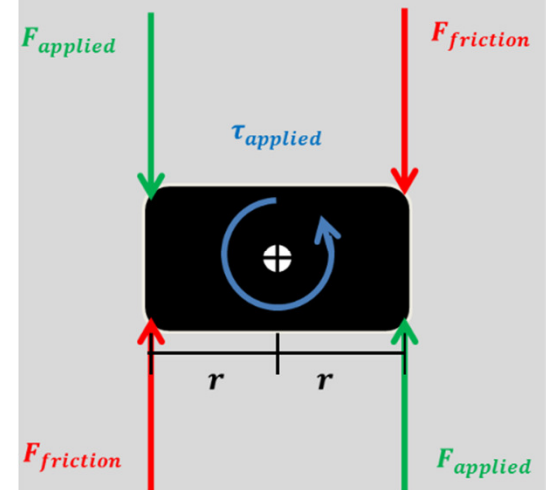

Motor Selection

$$P_{motor}(\omega) = -\left(\frac{\tau_s}{\omega_n}\right)\omega^2 + \tau_s\omega$$

$$P_{motor}(\tau) = -\left(\frac{\omega_n}{\tau_s}\right)\tau^2 + \omega_n\tau$$

D.C. Motor Torque/Speed Curve

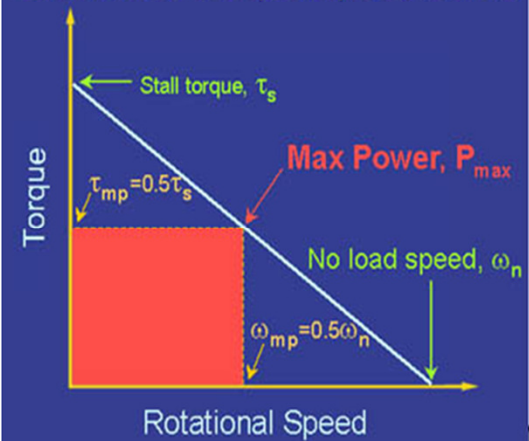

Conclusions

A numerical analysis will be compounded with observational inferences to determine a design most closely approximating the ideal product specifications from the customer.

A decision is now ready to be made based on the following:

1. Locomotion
2. Steering
3. Controls
4. Motor Selection
5. Spring Selection

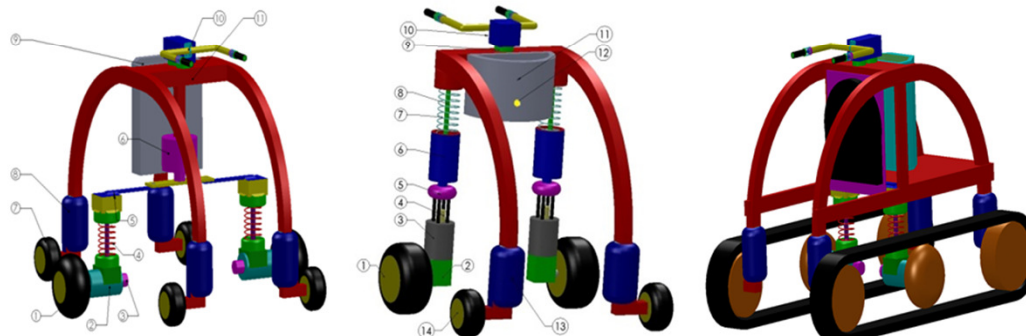

Sources

- http://www.delivery.superstock.com/WI/223/1838/PreviewComp/SuperStock_1838-8067.jpg
- http://en.wikipedia.org/wiki/File:Mass_spring_damper.png
- <http://dcacmotors.blogspot.com/2009/08/dc-motors-torquespeed-curves.html>
- <http://www.directindustry.com/prod/kistler/force-plates-5346-40016.html>
- http://www.robotcombat.com/store_tanktreads.html
- http://news.cnet.com/8301-13639_3-10098240-42.html

Questions?